

**Baxter**



**TL1 000**  
**EXAMINATION LIGHT**

---

# TL1000 EXAMINATION LIGHT

## DEVICE VERSIONS

Ceiling-mounted	x
Mobile Stand	x
Pendant-mounted	x
Wall-mounted	x

## REGISTRATION DATA

Classification (MDD)	1
Classification (MDR)	1
Classification (FDA)	2
Mark of Conformity	CE, UL

## LIGHTING DATA

Illumination Level at 1.0 m (Lux)	80,000
Dimmable from / to	100 - 30%; 3 steps
Pattern Size (d10) at 1.0 m (cm)	16.0 cm (6.3")
d50 / d10 Ratio	≥ 0.5
Color Temperature (K)	4,500
Color Rendering Index Ra	97
Color Rendering Index R9 (blood)	97
Color Rendering Index R13 (tissue)	98
Irradiance (W/m <sup>2</sup> ) <sup>1</sup>	380
Irradiance / Intensity ratio (mW/m <sup>2</sup> lx) <sup>2</sup>	3.5
EN ISO 60601-2-41 2nd Edition: Depth of Illumination (L1 + L2) at 20% Ec / 2nd Edition (cm)	140 cm (55.1")
EN ISO 60601-2-41 3rd Edition: Depth of Illumination (L1 + L2) at 60% Ec / 3rd Edition (cm)	93 cm (36.6")
Average Service Life of the LEDs (h)	> 50,000

<sup>1</sup>For illumination of 80,000 lux at a distance of 0.85m.

<sup>2</sup>In a distance of 1.0m at 80,000 lux.

Subject to changes

# TL1000 EXAMINATION LIGHT

## ELECTRICAL DATA

Power Pack Supply Voltage	100 - 240 V AC 50/60 Hz
Maximum Power Consumption of Total System (VA)	< 50
Maximum Thermal Load of the Light Head (W)	20

## MECHANICAL DATA

Light-emitting Surface (cm <sup>2</sup> )	240 (95.5 in <sup>2</sup> )
Laminar Flow Surface (cm <sup>2</sup> )	340 (133.9 in <sup>2</sup> )
Light Head Size (mm)	300 (11.8")
Weight of Light Head (incl. cardanic) (kg)	2.4 (5.3 lbs)

# TL1000 EXAMINATION LIGHT

## TL1000 CEILING, WALL AND MOBILE VERSION

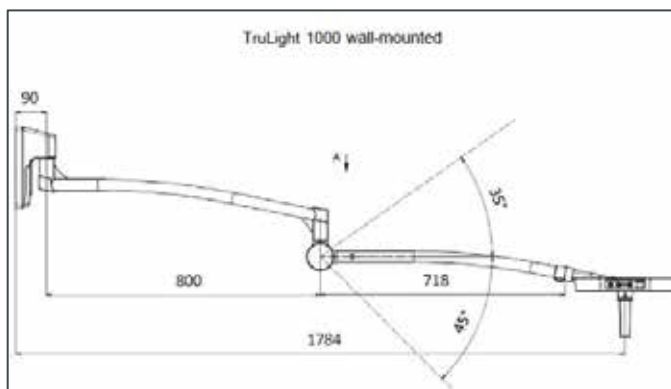
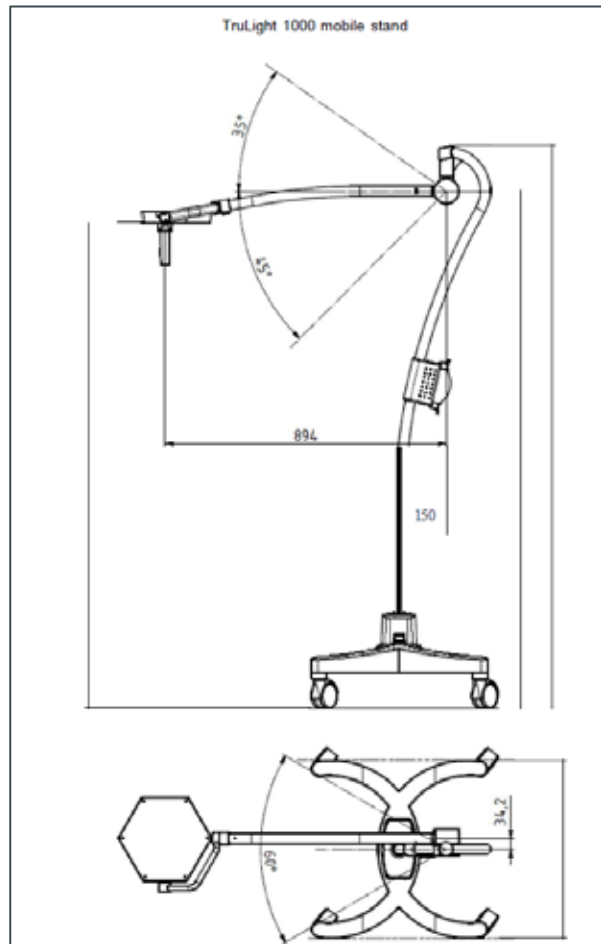
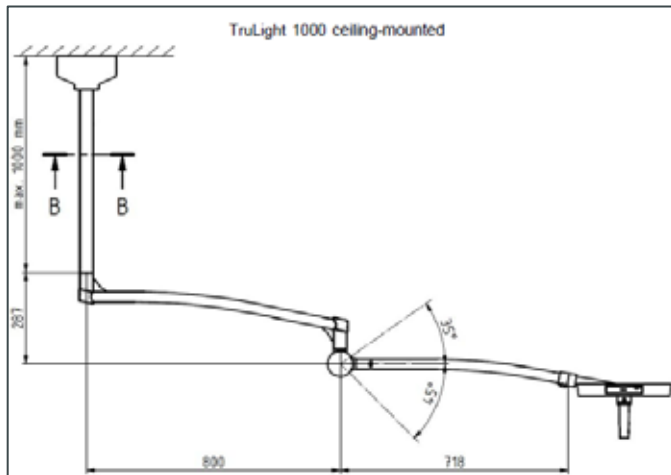

Subject to changes

For more information please contact your local Baxter representative.

[hillrom.com](http://hillrom.com)

The TL1000 Examination Light is intended to be used by clinicians and medically qualified personnel. This medical device is a regulated healthcare product which, pursuant to such regulation bears a CE mark. Baxter recommends that you carefully read the detailed instructions for safe and proper use included in the documents accompanying the medical devices. The personnel of healthcare establishments are responsible for the proper use and maintenance of these medical devices. Baxter reserves the right to make changes without notice in design, specifications and models. The only warranty Baxter makes is the express written warranty extended on the sale or rental of its products. Baxter Medical Systems GmbH + Co.KG.

Baxter and Hillrom are trademarks of Baxter International, Inc. or its subsidiaries. EMA-CS81-230001 v1 02/2023